

True Star

New project

ترو ستار



عقارات باغی شقلاوه

TOWER A

We designed for you

عقارات باغی شقلاوه

TOWER A *Type 1*

Floor plan

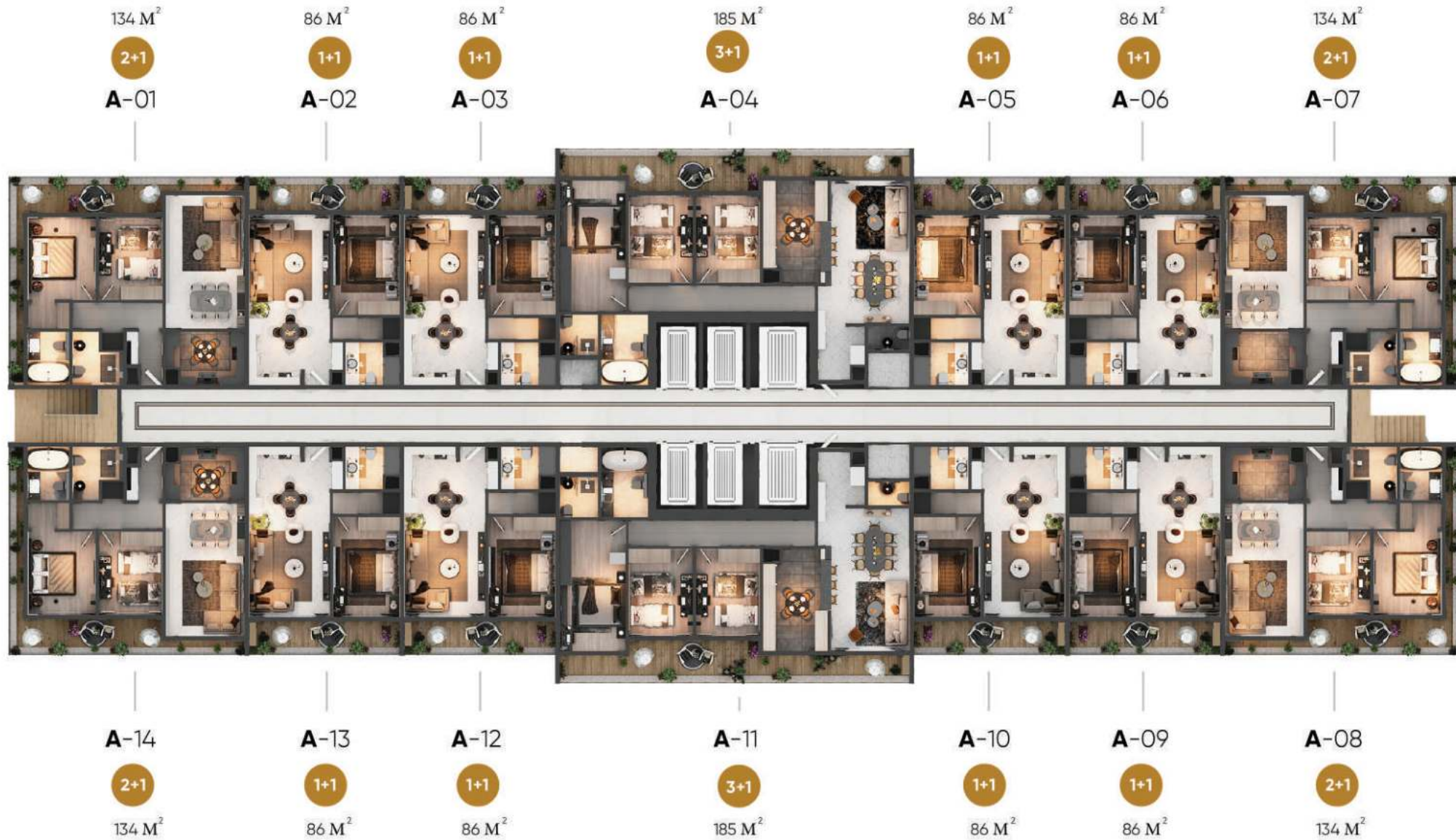

1st TO 22th F

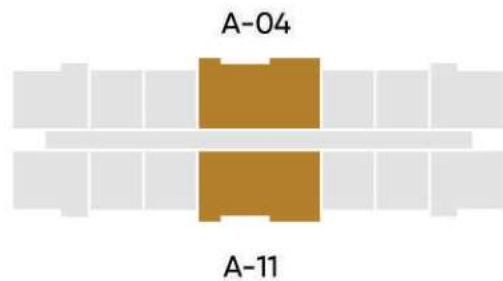

TOWER A

FLAT TYPE A (3+1)

1	• ENTRANCE	6 M ²
2	• LIVING ROOM & DINNIG	26.5 M ²
3	• KITCHEN	16 M ²
4	• BED ROOM 1	25 M ²
5	• BED ROOM 2	13.5 M ²
6	• BED ROOM 3	13.5 M ²
7	• BATH 1	7.5 M ²
8	• BATH 2	3 M ²
9	• CORRIDOR	13.5 M ²
10	• BALCONY	28 M ²

NET AREA
158.4 M²

GROSS AREA
185 M²

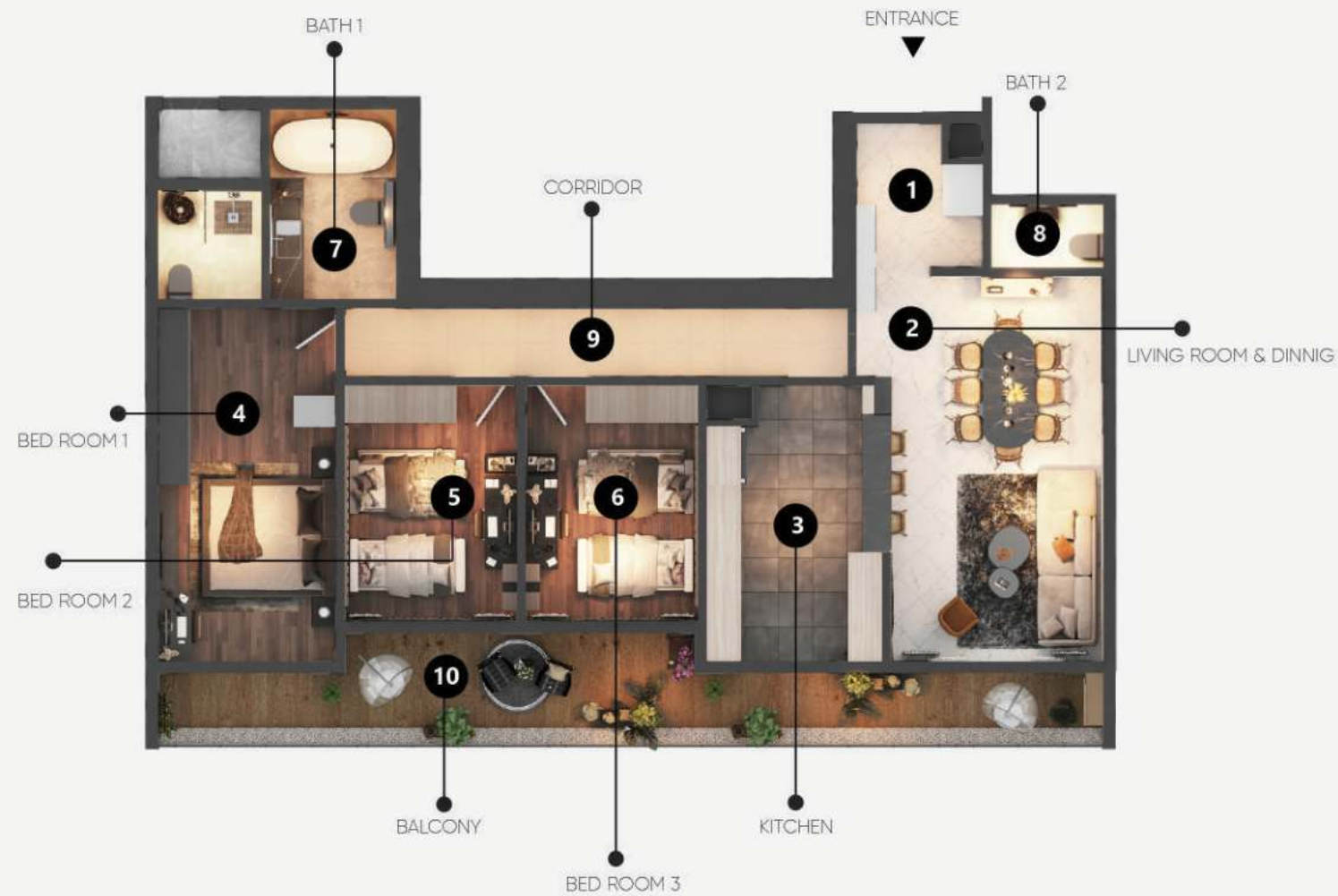

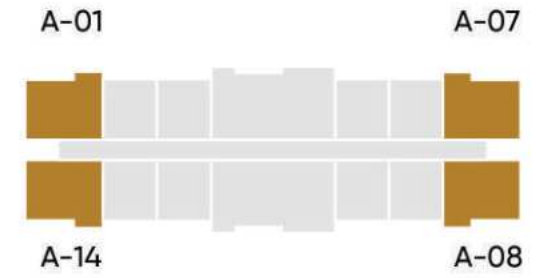

FLAT TYPE B (2+1)

1	• ENTRANCE	4.5 M ²
2	• LIVING ROOM & DINNIG	25 M ²
3	• KITCHEN	10.5 M ²
4	• BED ROOM 1	22.5 M ²
5	• BED ROOM 2	13 M ²
6	• BATH	6 M ²
7	• BATH 2	3 M ²
8	• CORRIDOR & LAUNDRY	7 M ²
9	• BALCONY	22.5 M ²



NET AREA
115 M²

GROSS AREA
134 M²

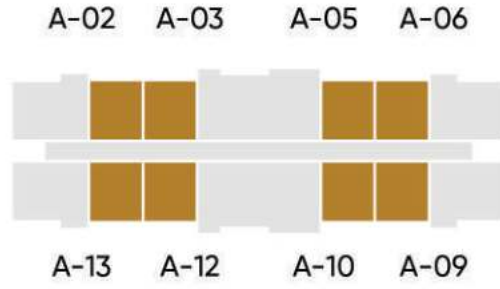

FLAT TYPE C (1+1)

1	• ENTRANCE	3.5 M ²
2	• LIVING ROOM	18 M ²
3	• KITCHEN & DINNIG	12 M ²
4	• BED ROOM	16.5 M ²
5	• BATH	5 M ²
6	• CORRIDOR & LAUNDRY	3.5 M ²
7	• BALCONY	12.5 M ²

NET AREA
73 M²

GROSS AREA
86 M²

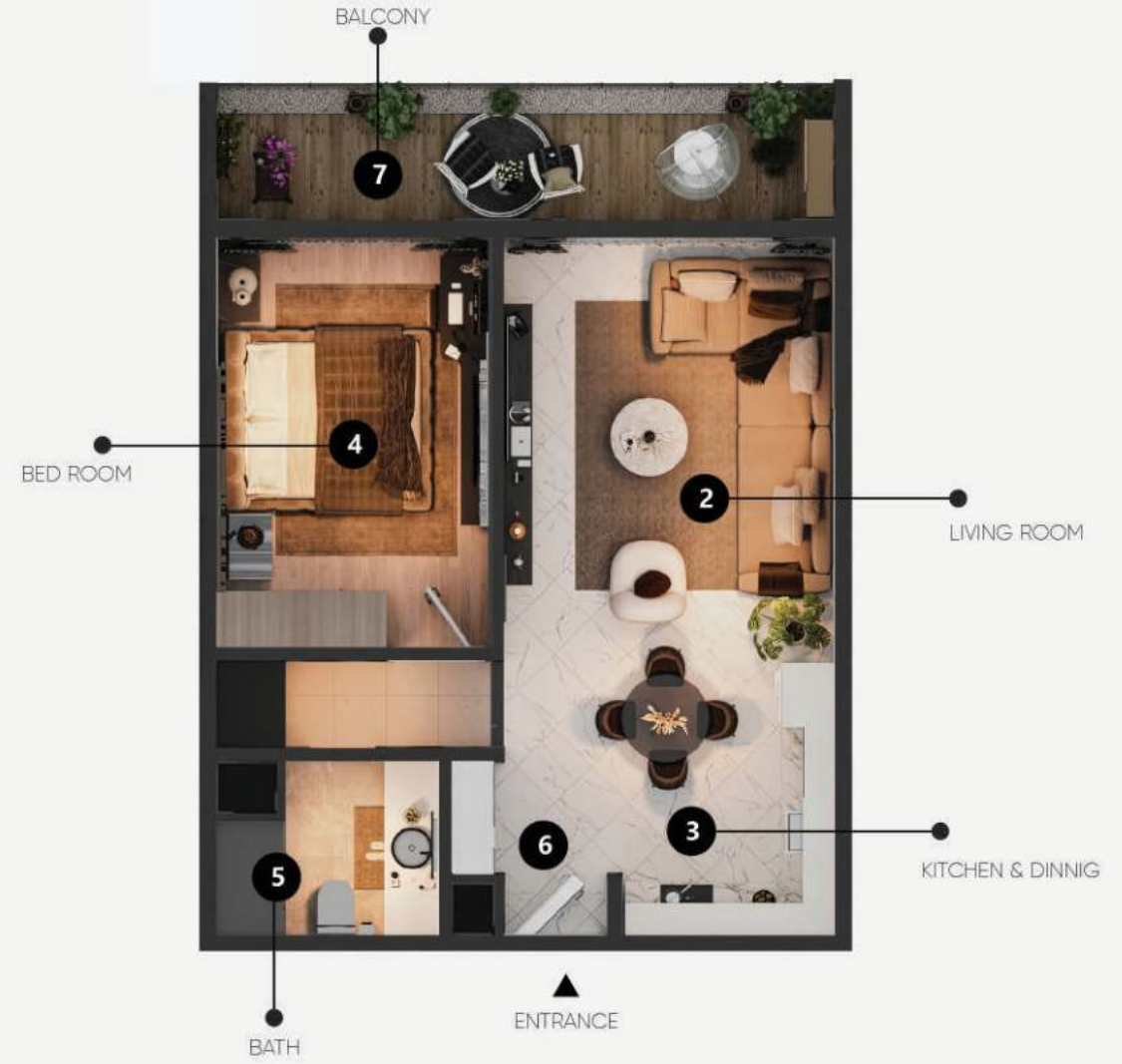

TOWER A *Type 2*

Floor plan

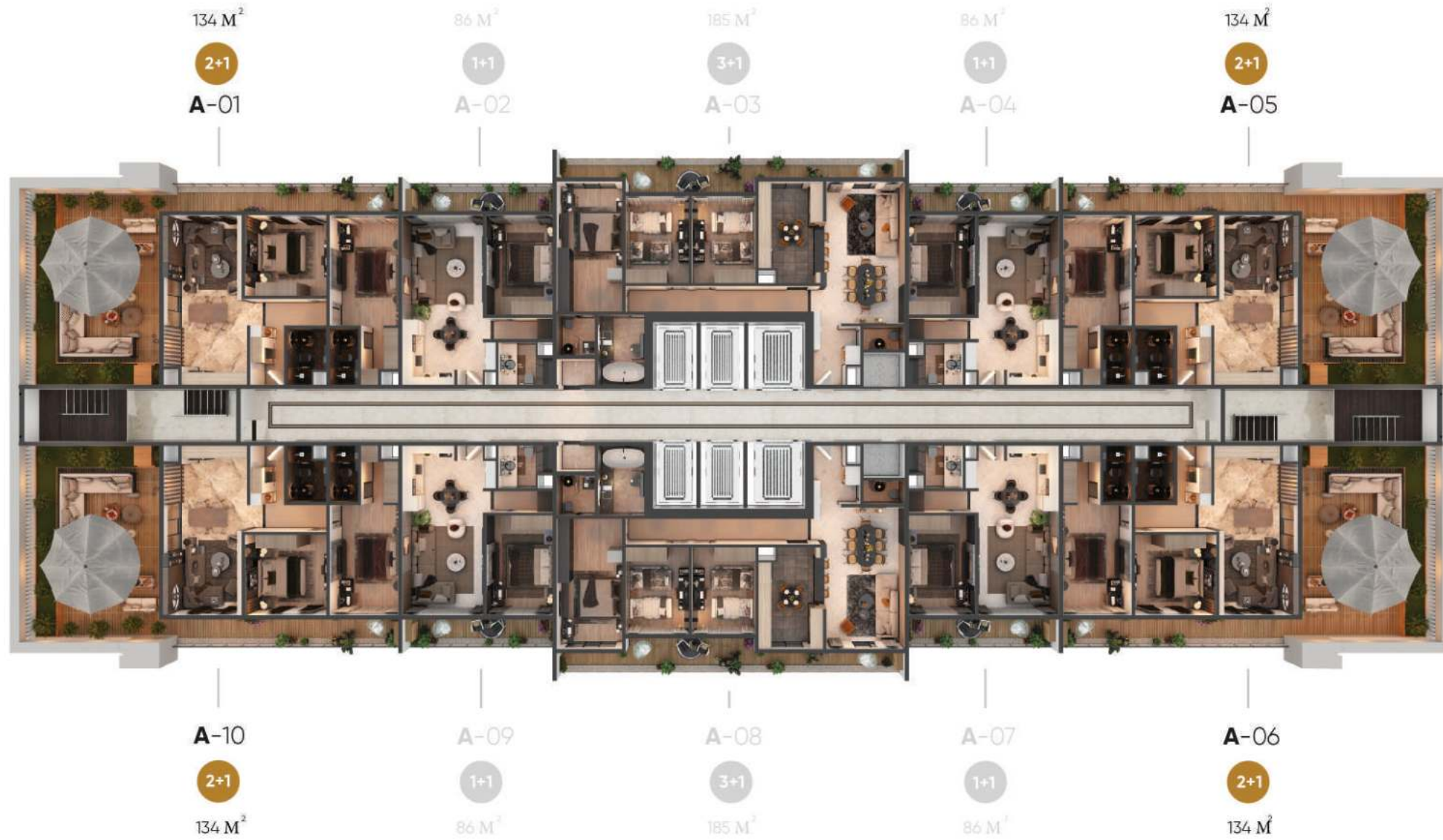

23th TO 37th F

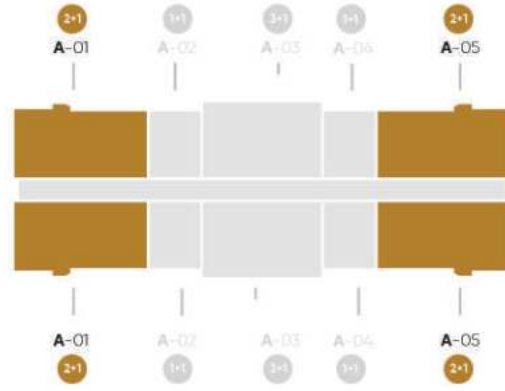

FLAT TYPE E (2+1)

WITH ROOF GARDEN

1	• ENTRANCE	4.5 M ²
2	• LIVING ROOM & DINNIG	25 M ²
3	• KITCHEN	10.5 M ²
4	• BED ROOM 1	22.5 M ²
5	• BED ROOM 2	13 M ²
6	• BATH	6 M ²
7	• CORRIDOR & LAUNDRY	7 M ²
8	• BALCONY	22.5 M ²

NET AREA
113 M²

GROSS AREA
134 M²

ROOF GARDEN
74 M²

TOWER A

TRUE STAR
TOWERS

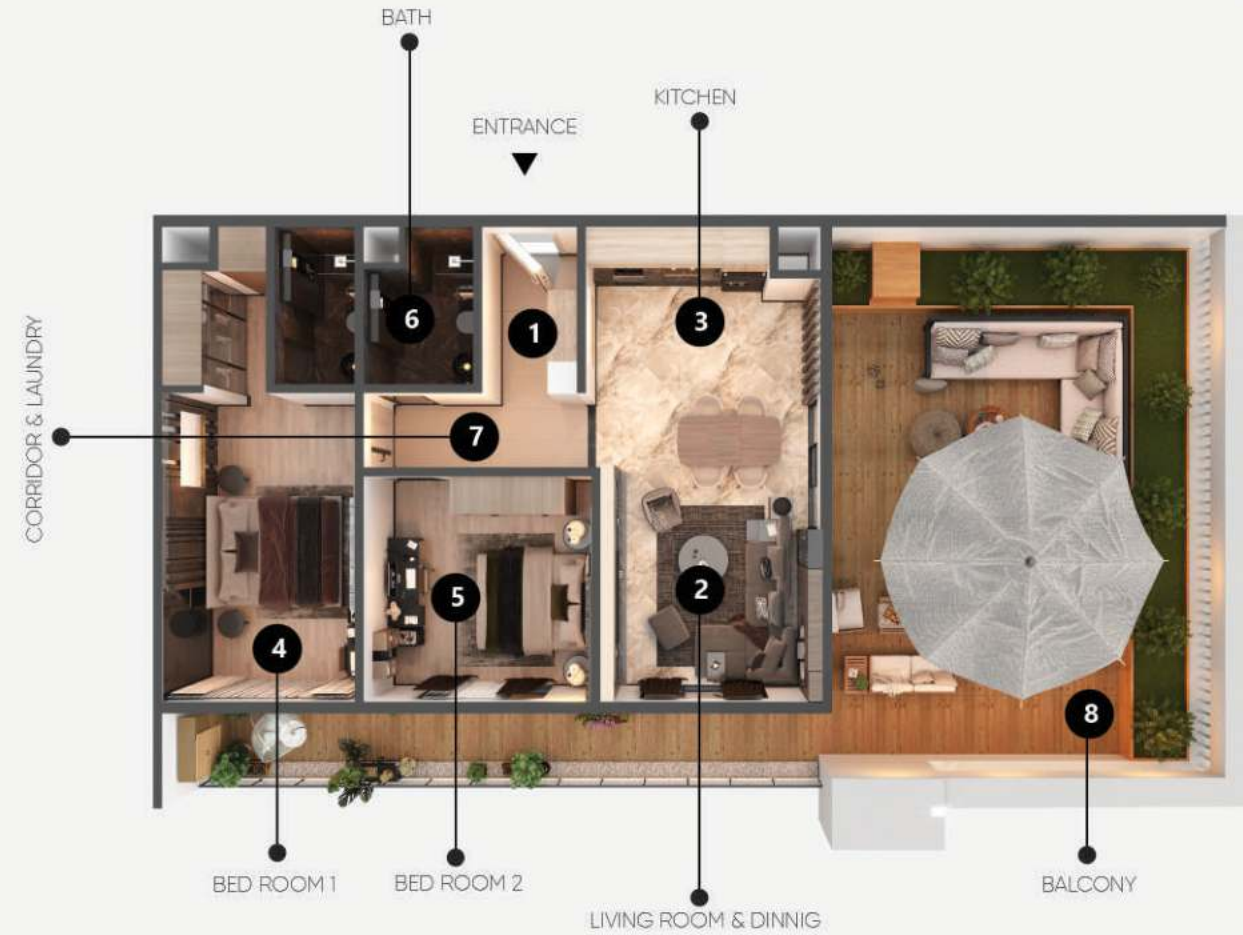

عقارات باغی شقلاوه

TOWER A

Type 3
Floor plan

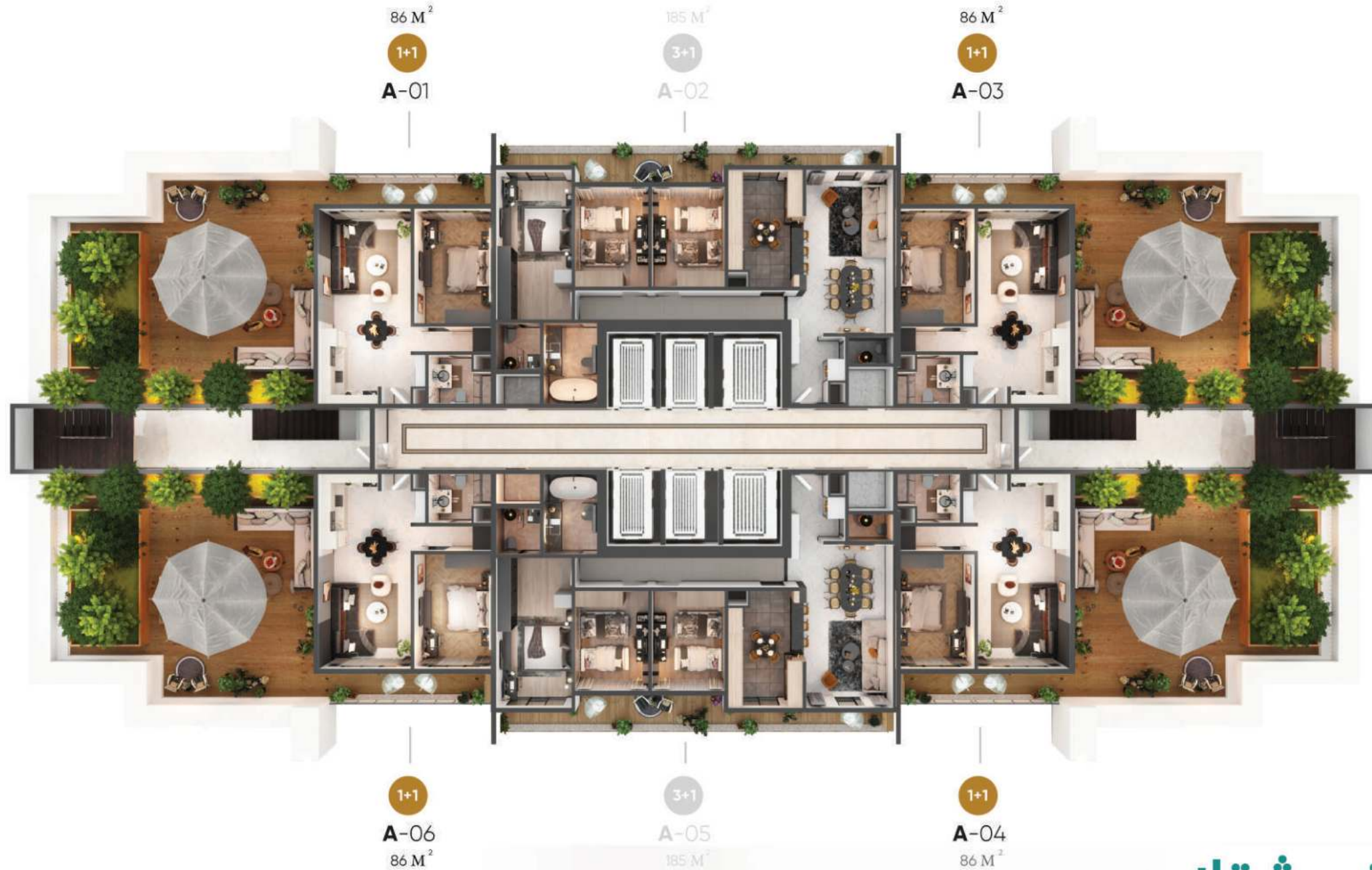

38th TO 40th F.

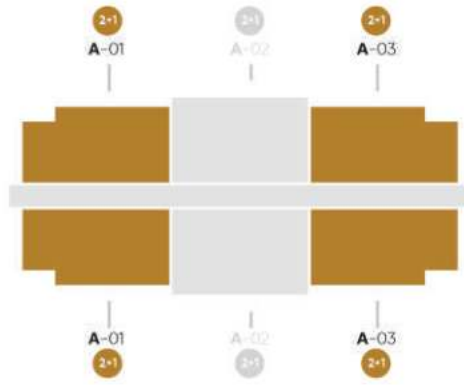

TOWER A

FLAT TYPE F (1+1)

WITH ROOF GARDEN

1	• ENTRANCE	3.5 M ²
2	• LIVING ROOM	18 M ²
3	• KITCHEN & DINNIG	12 M ²
4	• BED ROOM	16.5 M ²
5	• BATH	5 M ²
6	• CORRIDOR & LAUNDRY	3.5 M ²
7	• BALCONY	12.5 M ²

NET AREA
73 M²

GROSS AREA
86 M²

ROOF GARDEN
106.5 M²



TOWER B-C

we design for you

عقارات باغی شقلاوه

TOWER B-C

Floor plan



1nd TO 10th F.

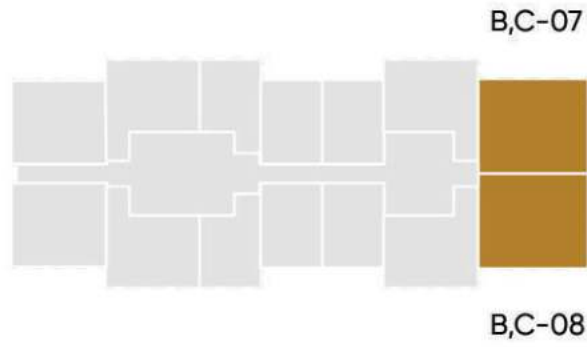

TOWER B-C

FLAT TYPE A (3+1)

1	• ENTRANCE	6.5 M ²
2	• LIVING ROOM & DINNIG	29 M ²
3	• KITCHEN	11,5 M ²
4	• BED ROOM 1	21.5 M ²
5	• BED ROOM 2	14 M ²
6	• BED ROOM 3	14 M ²
7	• BATH 1	5 M ²
8	• BATH 2	3 M ²
9	• CORRIDOR & LAUNDRY	14.5 M ²
10	• BALCONY	38 M ²

NET AREA
158.5 M²

GROSS AREA
190.6 M²

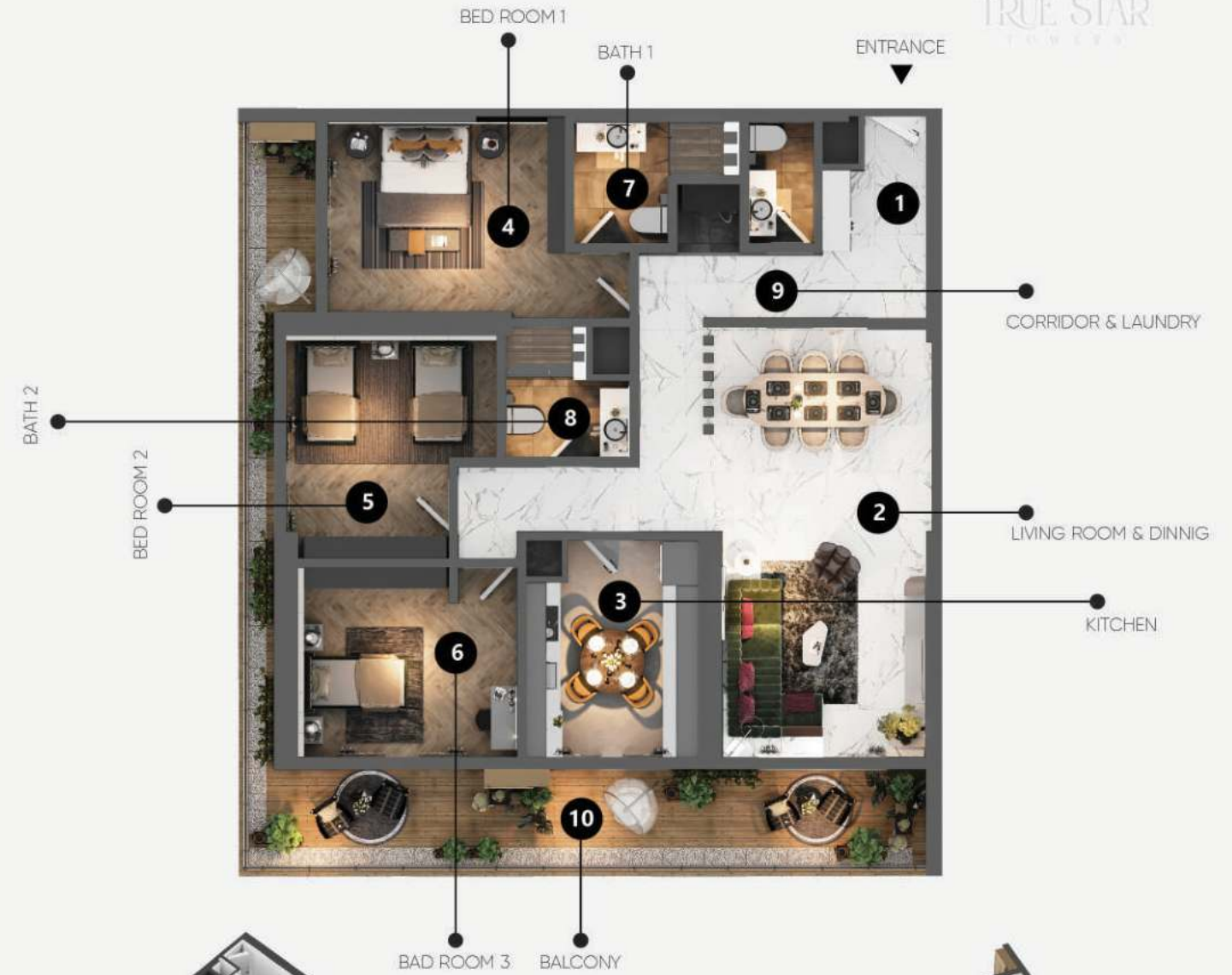

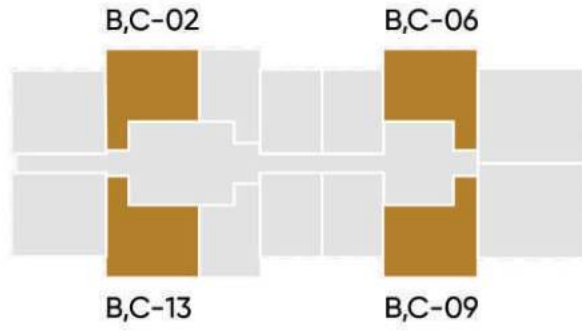

TOWER B-C

FLAT TYPE B (2+1)

1	• ENTRANCE	5.5 M ²
2	• LIVING ROOM	18 M ²
3	• KITCHEN & DINNIG	17 M ²
4	• BED ROOM 1	23 M ²
5	• BED ROOM 2	11 M ²
6	• BATH	5 M ²
7	• CORRIDOR & LAUNDRY	6 M ²
8	• BALCONY	23.5 M ²

NET AREA
105.5 M²

GROSS AREA
127.1 M²



B,C-01

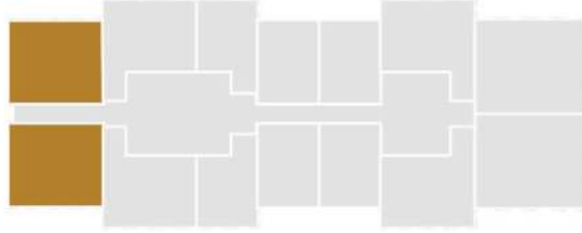

B,C-14

TOWER B-C

FLAT TYPE C (2+1)

1	• ENTRANCE	6 M ²
2	• LIVING ROOM	18 M ²
3	• KITCHEN & DINNIG	13,5 M ²
4	• BED ROOM 1	21.5 M ²
5	• BED ROOM 2	15.5 M ²
6	• BATH	5 M ²
7	• CORRIDOR	6.5 M ²
8	• BALCONY	12.5 M ²

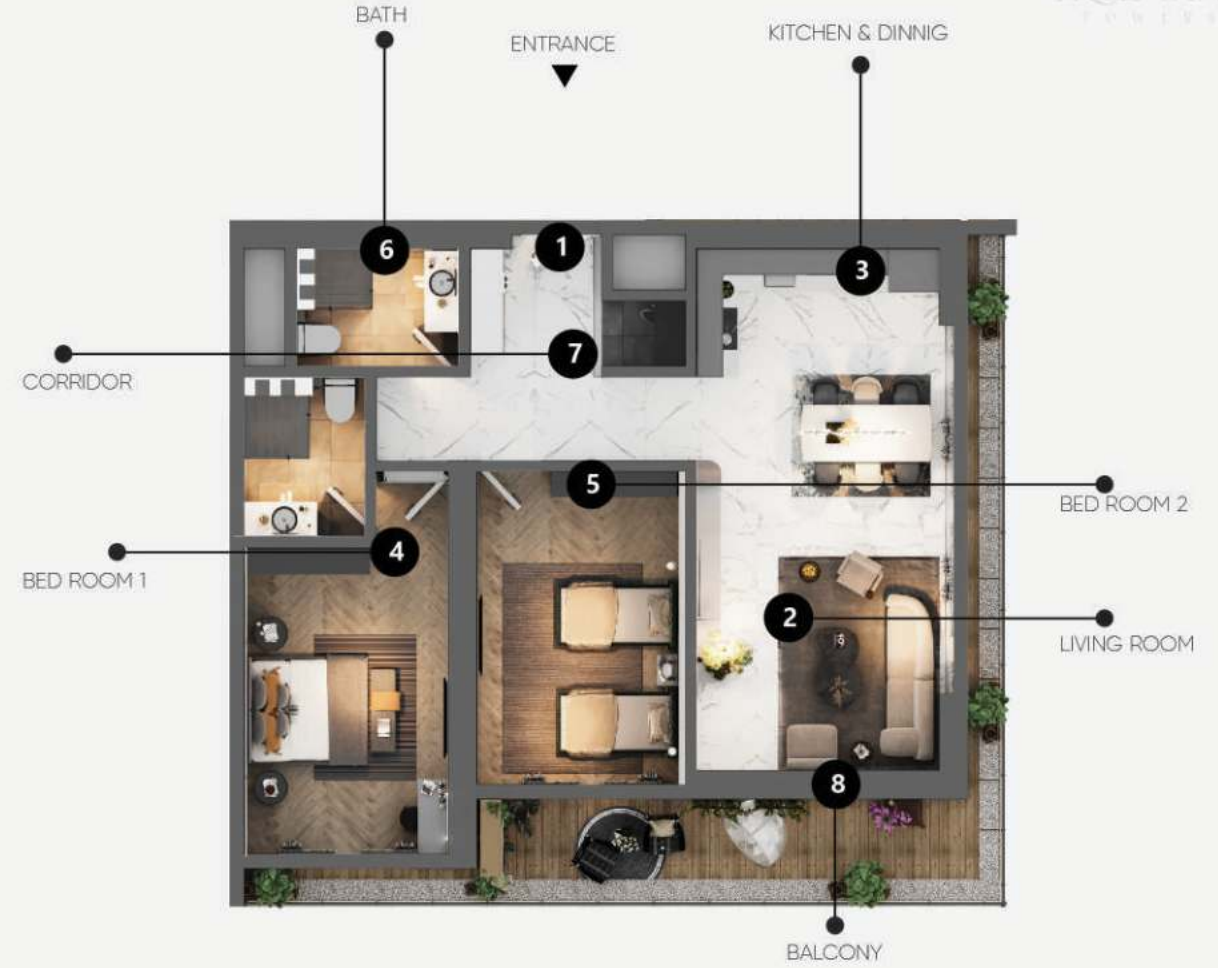

NET AREA
115.5 M²

GROSS AREA
138.5 M²



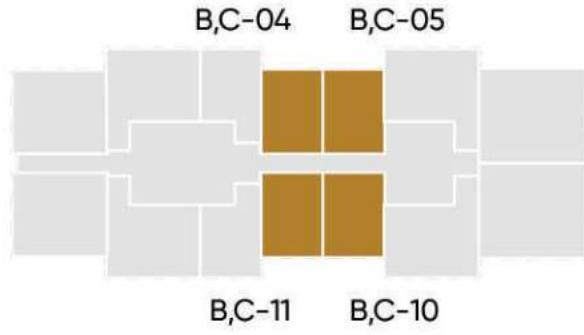

TOWER B-C

FLAT TYPE D (1+1)

1	• ENTRANCE	4 M ²
2	• LIVING ROOM	18.5 M ²
3	• KITCHEN & DINNIG	12,5 M ²
4	• BED ROOM	16.5 M ²
5	• BATH	5.5 M ²
6	• CORRIDOR & LAUNDRY	4 M ²
7	• BALCONY	12.5 M ²

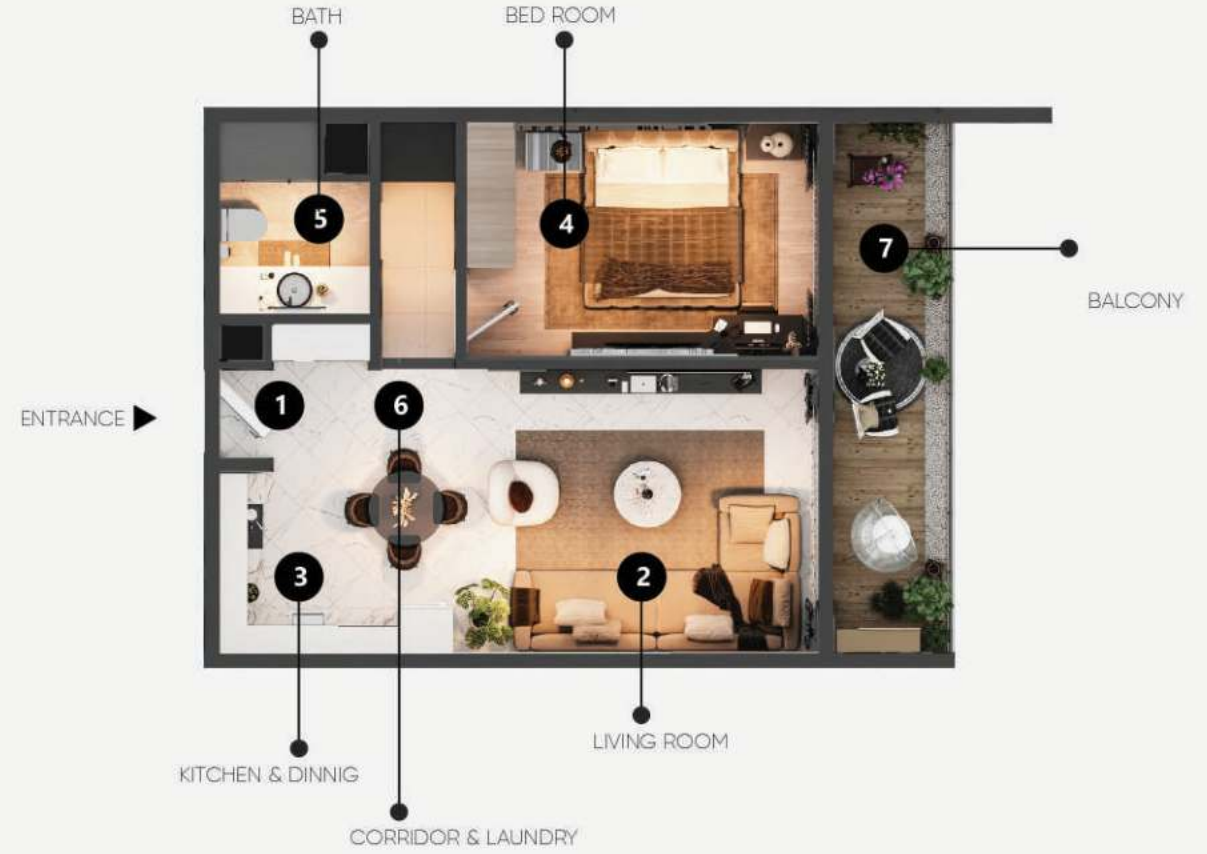

NET AREA
74.8 M²

GROSS AREA
89.8 M²

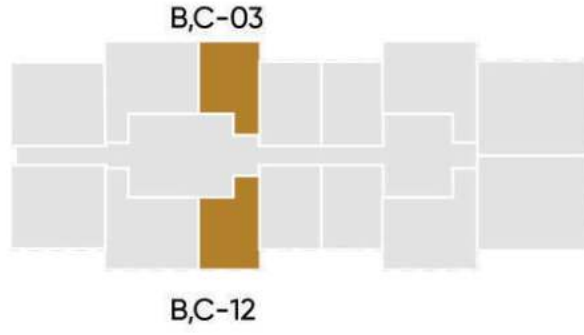

TOWER B-C

FLAT TYPE E (1+1)

1	• ENTRANCE	3 M ²
2	• LIVING ROOM	15 M ²
3	• KITCHEN & DINNIG	15 M ²
4	• BED ROOM	17.5 M ²
5	• BATH	6 M ²
6	• CORRIDOR & LAUNDRY	3 M ²
7	• BALCONY	10.5 M ²



NET AREA
72.7 M²

GROSS AREA
87.5 M²

TOWER B-C

Floor plan



11th TO 18th F.

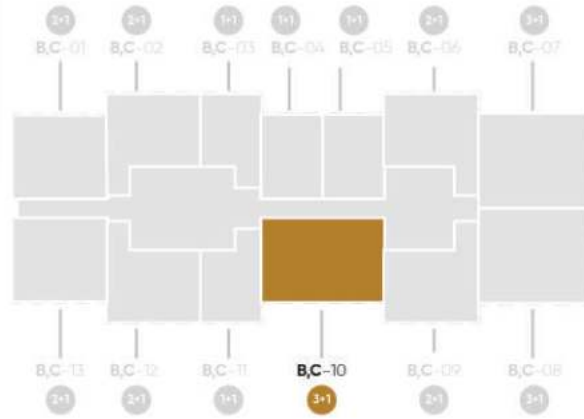

FLAT TYPE F (3+1)

1	• ENTRANCE	5 M ²
2	• LIVING ROOM & DINNIG	31 M ²
3	• COLD KITCHEN	8.5 M ²
4	• HOT KITCHEN	8,5 M ²
5	• BED ROOM 1	34 M ²
6	• BED ROOM 2	17 M ²
7	• BED ROOM 3	17 M ²
8	• BATH 1	7 M ²
9	• BATH 2	3 M ²
10	• CORRIDOR	9 M ²
11	• BALCONY	11 M ²

NET AREA
147.7 M²

GROSS AREA
179.6 M²

TOWER B-C



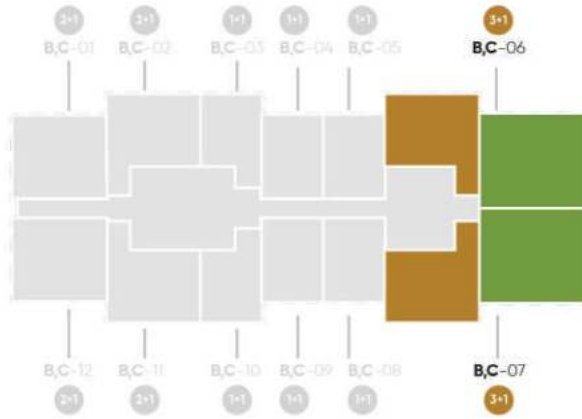

FLAT TYPE G (2+1)

WITH ROOF GARDEN

- | | | |
|---|----------------------|---------------------|
| 1 | • ENTRANCE | 5.5 M ² |
| 2 | • LIVING ROOM | 18 M ² |
| 3 | • KITCHEN & DINNIG | 17 M ² |
| 4 | • BED ROOM 1 | 23 M ² |
| 5 | • BED ROOM 2 | 11 M ² |
| 6 | • BATH | 5 M ² |
| 7 | • CORRIDOR & LAUNDRY | 4 M ² |
| 8 | • BALCONY | 12.5 M ² |

NET AREA
105.5 M²

GROSS AREA
127.1 M²

ROOF GARDEN AREA
159 M²

TOWER B-C



19th to 22th floors

عقارات باغی شقلاوه

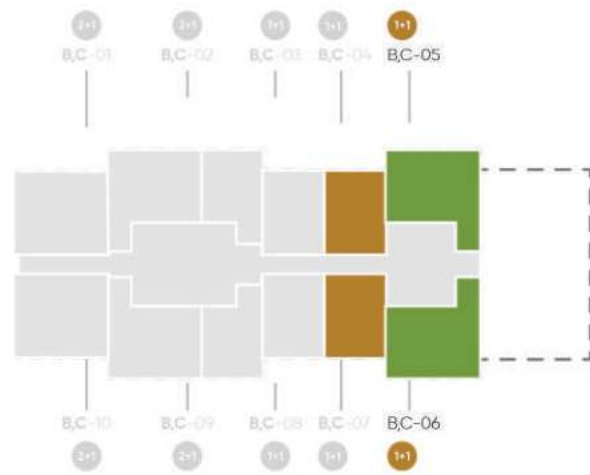

TOWER B-C

FLAT TYPE H (1+1)

WITH ROOF GARDEN

- | | | |
|---|----------------------|---------------------|
| 1 | • ENTRANCE | 4 M ² |
| 2 | • LIVING ROOM | 18.5 M ² |
| 3 | • KITCHEN & DINNIG | 12.5 M ² |
| 4 | • BED ROOM | 16.5 M ² |
| 5 | • BATH | 5.5 M ² |
| 6 | • CORRIDOR & LAUNDRY | 4 M ² |
| 7 | • BALCONY | 12.5 M ² |

NET AREA
74.8 M²

GROSS AREA
89.8 M²

ROOF GARDEN AREA
96 M²



23th to 26th floors

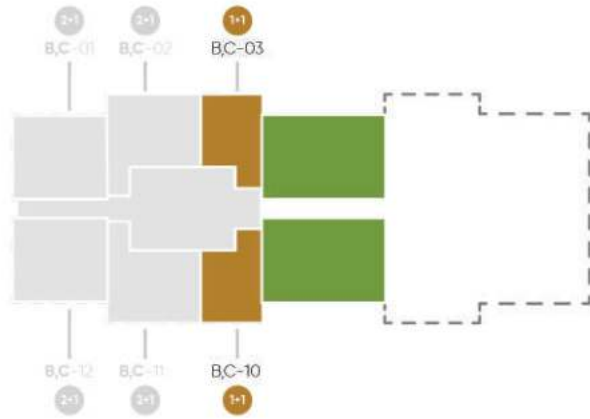

FLAT TYPE I (1+1)

WITH ROOF GARDEN

1	• ENTRANCE	3 M ²
2	• LIVING ROOM	15 M ²
3	• KITCHEN & DINNIG	15 M ²
4	• BED ROOM	17.5 M ²
5	• BATH	6 M ²
6	• CORRIDOR & LAUNDRY	3 M ²
7	• BALCONY	10.5 M ²

NET AREA
72.7 M²

GROSS AREA
87.5 M²

ROOF GARDEN AREA
162 M²

TOWER B-C

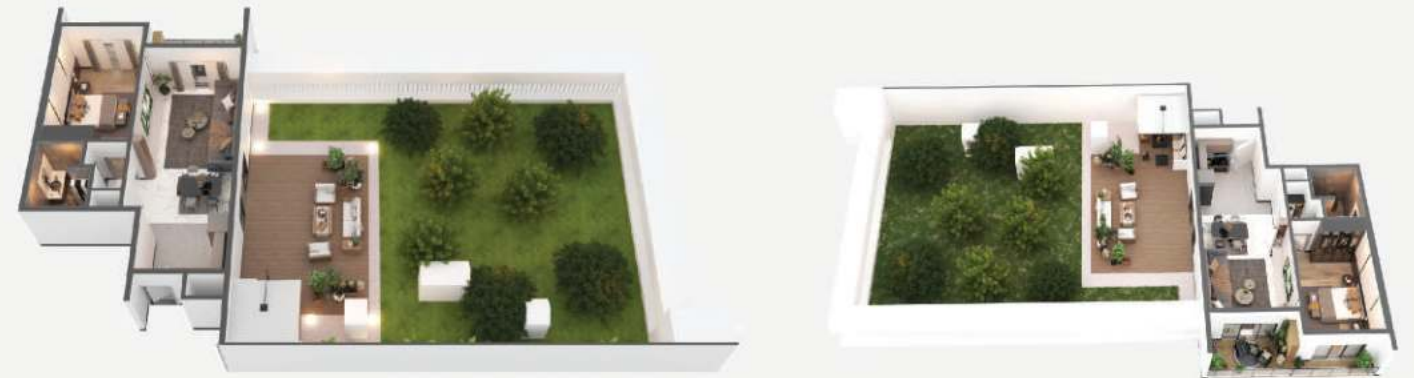

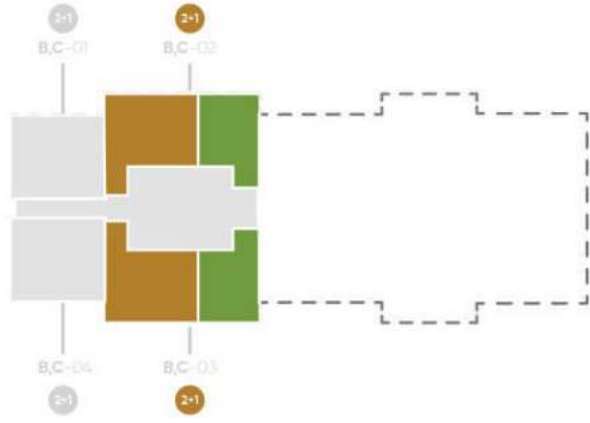

DUPLEX FLOOR. (2+1)

WITH ROOF GARDEN

1	• ENTRANCE	17	M ²
2	• LIVING ROOM	10	M ²
3	• KITCHEN & DINNIG	17	M ²
4	• RECEPTION	29	M ²
5	• BATH	6.2	M ²
6	• CORRIDOR	4.8	M ²
7	• BALCONY	19	M ²

NET AREA
208 M²

GROSS AREA
253.2 M²

ROOF GARDEN AREA
76 M²

TOWER B-C



Duplex - Ground floor

31th to 34th floors

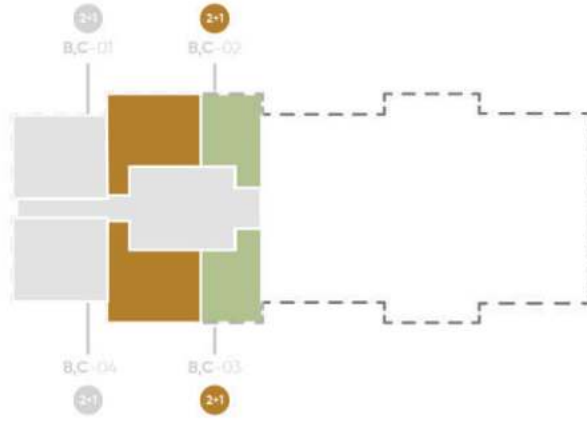

DUPLEX FLOOR. (2+1)

WITH ROOF GARDEN

8	• MASTER BEDROOM	36.2 M ²
9	• KIDS BEDROOM	16.7 M ²
10	• BATH	7.9 M ²
11	• CORRIDOR	17.5 M ²
12	• DUPLEX OPEN	8.7 M ²

NET AREA
208 M²

GROSS AREA
253.2 M²

ROOF GARDEN AREA
76 M²

TOWER B-C



Duplex - First floor

31th to 34th floors



نرخه‌کانی | ترو ستار

قستی 5 سال	%40 بری ماهه	%22 راده ستکردن	%20 ته‌واو بوونی هه‌یکه‌ل	%18 پیشه‌کی	نرخه گشتی	نرخه 1 مه‌تر	رو به‌ر	چۆر
---------------	-----------------	--------------------	---------------------------------	----------------	-----------	-----------------	---------	-----

\$ 418	\$25.112.00	\$13,811.60	\$12.556.00	\$11.300.40	\$62,780	730\$	86 م ²	1+1
\$ 425	\$25.550.00	\$14.052.50	\$12.775.00	\$11.497.50	\$63,875	730\$	87.5 م ²	1+1
\$ 437	\$26.221.60	\$14.421.88	\$13.110.80	\$11.799.72	\$65,554	730\$	89.8 م ²	1+1
\$ 618	\$37.113.20	\$20.412.26	\$18.556.60	\$16.700.94	\$92,783	730\$	127.1 م ²	1+2
\$ 652	\$39.128.00	\$21.520.40	\$19.564.00	\$17.607.60	\$97,820	730\$	134 م ²	1+2
\$ 678	\$40.734.00	\$22.403.70	\$20.367.00	\$18.330.30	\$101,835	730\$	139.5 م ²	1+2
\$ 866	\$52.005.20	\$28.602.86	\$26.002.60	\$23.402.34	\$130,013	730\$	178.1 م ²	1+3
\$ 900	\$54.020.00	\$29.711.00	\$27.010.00	\$24.309.00	\$135,050	730\$	185 م ²	1+3
\$ 927	\$55.655.20	\$30.610.36	\$27.827.60	\$25.044.84	\$139,138	730\$	190.6 م ²	1+3